

**URS1 Hardware List**

- 2 or 3 – Steel Slotted Uprights
- 2 or 3 – 3/8-16 x 3" Fully Threaded Hex Head Cap Screw
- 1 – 3/8-16 x 3" Fully Threaded Socket Head Cap Screw
- 2 or 3 – 3/8" Flat Washer
- 2 or 3 – 3/8" Lock Washer
- (Quantities vary with size of table)

\*Center uprights on Tech Center tables use a socket head bolt instead of hex head.

See page 4 for details.

The work surface will be pre-drilled for mounting of steel slotted uprights. Line up each upright over the hole provided so that the open faces of the uprights are facing the center of the table. See Table 1 for upright spacing. If provided a third upright, the upright with wider slots will be used as the center upright. This is to accommodate two sets of shelf brackets. Fasten each upright to the work surface using 3/8-16 x 3" fully threaded hex head cap screws, 3/8" flat washers, and 3/8" lock washers. The uprights must be parallel with the edge of the work surface when tight. (See *fig-3*)

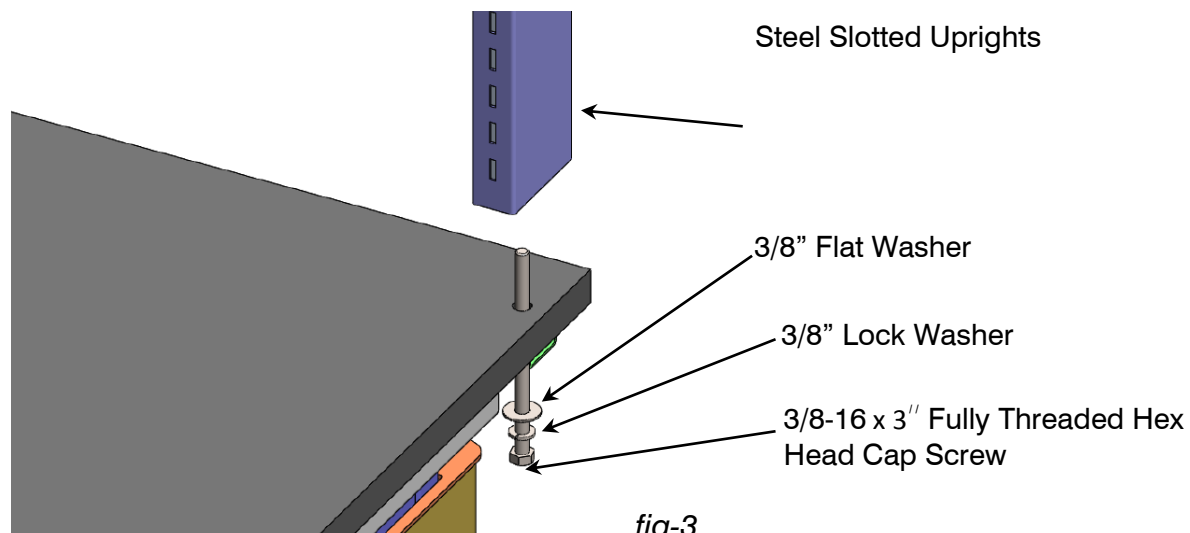

*fig-3*